

TOP  
scale 1:2

249.7328mm  
(9.832")

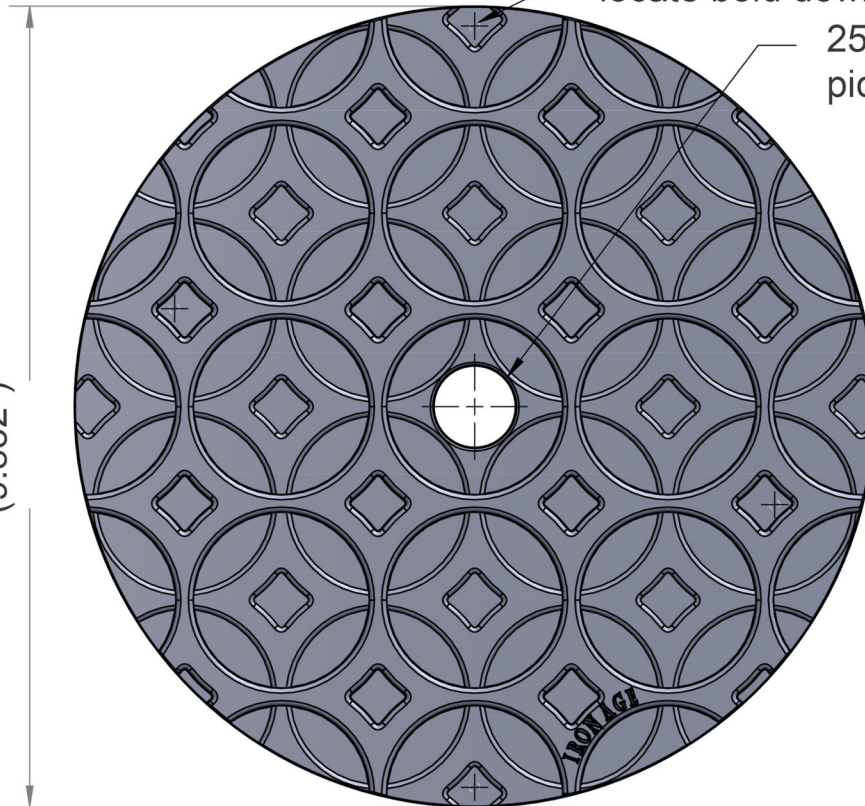

(x4) drill point - on rear - to locate bold down holes

25.4 dia. pick hole

BACK  
scale 1:3

(x4) drill point to locate bold down holes

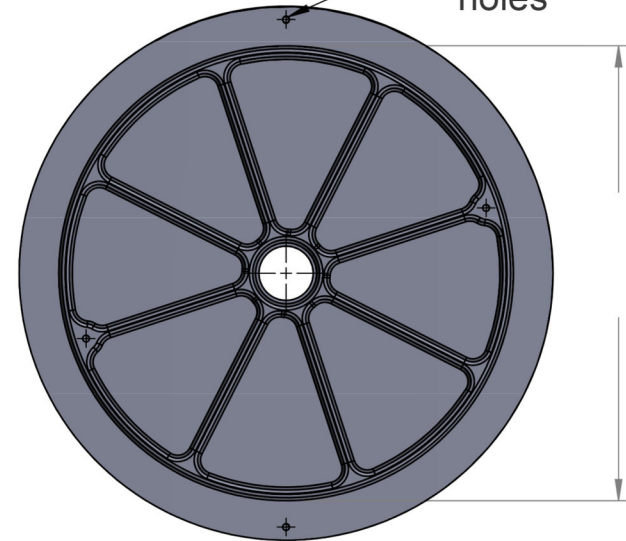

212.725mm  
(8.375")



SIDE  
scale 1:2

12.7

5.08

17.78 total

ISOMETRIC  
scale 1:3

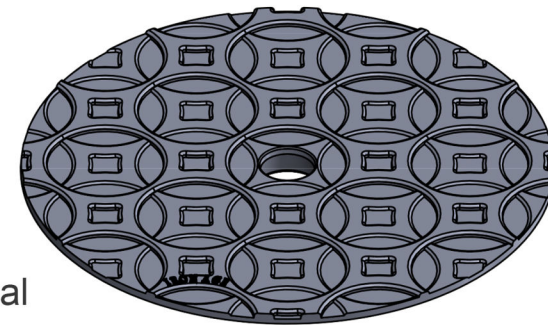

Pattern : Interlaken

Material : Cast Bronze

Interlaken 250mm Skimmer Lid

Interlaken 10" Dia. Skimmer Lid

Finish : Patina

Thickness : 17.78

Drawing no : INT-SL-250

Product no : CI66-250SL

Dimensions : 249,7328

Units : mm



Unit 5 Cotswold Business Park  
Millfield Lane  
Beds LU1 4AJ

Load Class : N/A

Flow rate : N/A

info@lateraldesignstudio.co.uk

0208 450 2244