

3 CASTINGS ARRAYED

scale 1:7

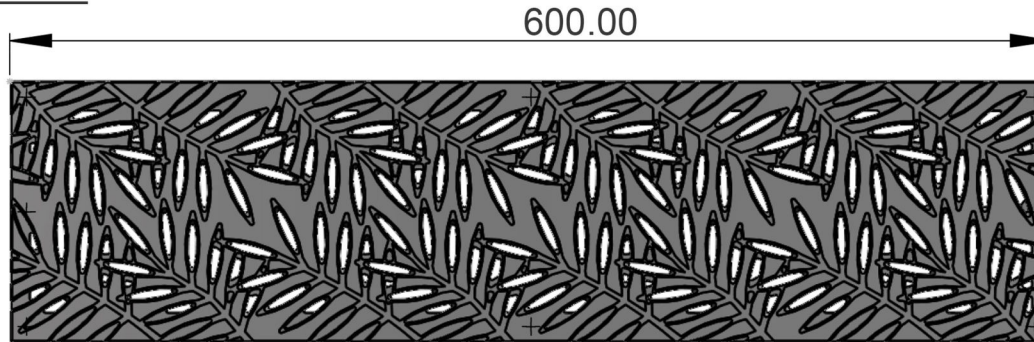

TOP
scale 1:4

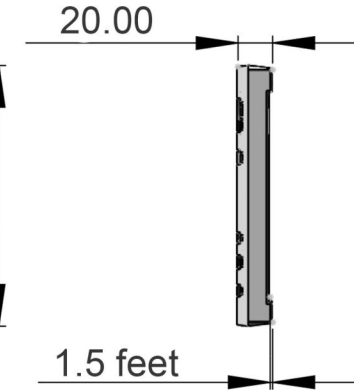

END
scale 1:4



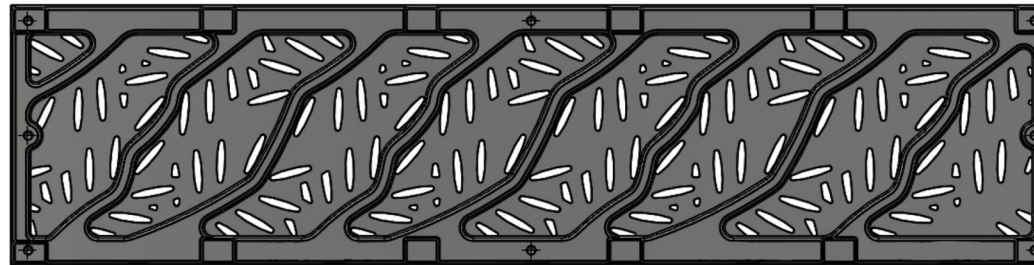

EDGE
scale 1:4



BACK
scale 1:4

(x8) drill point to locate bolt - down hole

| | | | | |
|---|-------------------------|----------------------|--|---|
|  <p>IRON AGE DESIGNS www.ironagegrates.co.uk</p> | Pattern : Locust | Material : Cast Iron | Locust 600 x 150 mm Channel Grate <small>Locust trench cover 150mm x 600mm</small> | |
| | Finish : Natural Finish | Thickness : 20 | Drawing no : LOC-CG-600-150 Product no : CI65-600-150CG | |
| 1. Due to casting inconsistencies all dimensions are nominal 2. No openings greater than 6.00 mm 3. Please discuss about channel drain options | Dimensions : 600 x 150 | Units : mm |  <p>LATERAL DESIGN STUDIO <small>www.lateraldesignstudio.co.uk</small></p> | Unit 5 Cotswold Business Park Millfield Lane Beds LU1 4AJ |
| | Load Class : N/A | Flow rate : N/A | | |
| <small>Copyright 2011-2016 Lateral Design Studio Limited. This drawing and subject matter disclosed therein, embody proprietary information which is the confidential property of Lateral Design Studio Ltd, none of which shall be copied, reproduced, disclosed to others, published or used, in whole or in part, without the express advanced written permission of a duly authorised agent of the company.</small> | | |  | |