

Issue	Date	Description	Name
A	19.5.2016	Detail Drawn	MP

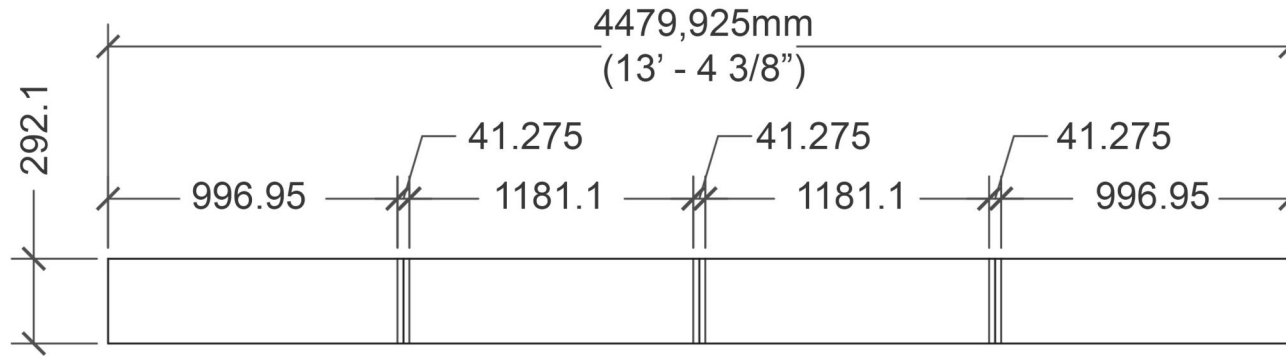

Framing Layout
scale 1/4 X



Castings Arrayed
scale 1/4 X

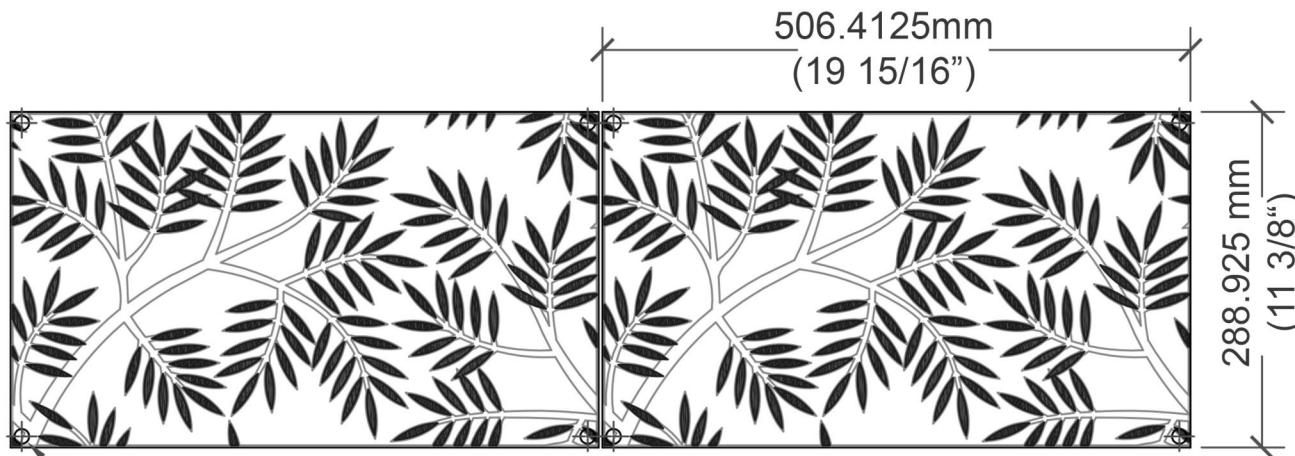

TOP
scale 1X

Please provide information on location of drill points for the drilling of bolt down holes.
Drilling and tapping to be done in field by contractor



Pattern : Locust

Material : Cast Ductile Iron

Locust 506 x 288 mm Channel Grate

Loyola Bridge Stair grate

Finish : Natural Finish

Thickness : 22.225

Drawing no : LOC-CG-506-288 Product no : CI65-506-288CG

Dimensions : 506,4125 x 288,925

Units : mm



Unit 5 Cotswold Business Park
Millfield Lane
Beds LU1 4AJ

Load Class : N/A

Flow rate : 9%

info@lateraldesignstudio.co.uk

0208 450 2244

